

Micropolis 3243WD (Wide, Differential) Disk Drive Configuration/Specification Data Sheet

Formatted Capacity

Per Drive	4,294 MB
Bytes per Sector	512
Sectors per Track	Variable
Cylinders	3,956

Performance Specifications

Avg. Seek Time (includes read settling time)	8.9 msec
Avg. Rotational Latency	4.17 msec
Rotational Speed	7,200 rpm \pm .05%
Data Transfer Rate at Interface	
Synchronous	20 MB/sec
Asynchronous	10 MB/sec
Internal Data Rate	46 - 80 Mbits/sec
MTBF (power-on hours)	650,000 (Office Environment)
Positioner	Fully balanced rotary voice coil
Parking	Automatic park and lock

General Functional Specifications

Interface	Fast SCSI-2
Supports Full Common Command Set	Yes
Drivers/Receivers	Wide, Differential

Power Requirements

+12V \pm 5% (average)	0.9 A
+12V \pm 5% (max during start-up)	1.66 A
+5V \pm 5% (average)	1.0 A
Power Dissipation, typical	
Idling	16 Watts (54.6 Btu/hr)
Writing	17.2 Watts (58.7 Btu/hr)
Reading	19.2 Watts (65.5 Btu/hr)
Seeking	18 Watts (61.4 Btu/hr)

Configuration Option Selection

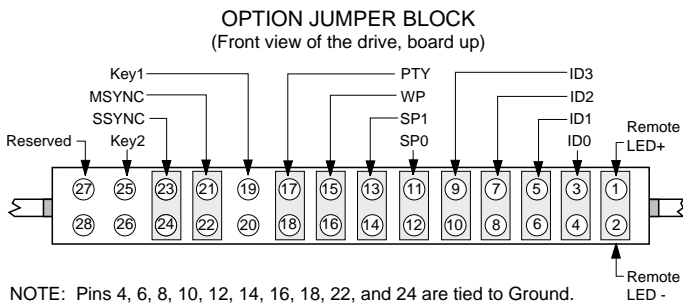
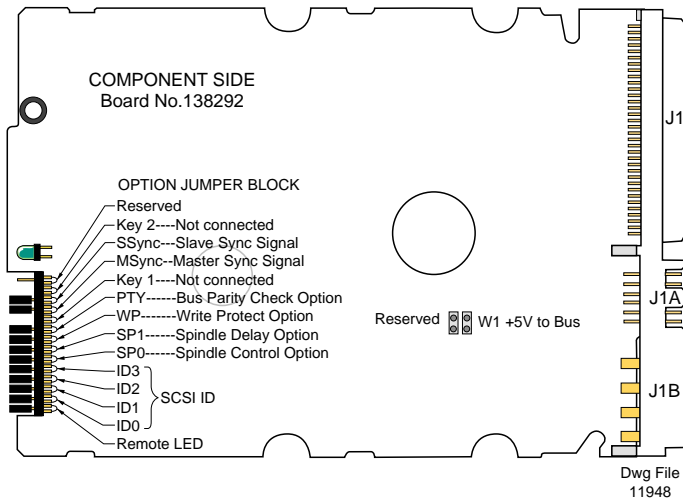

SCSI ID

Up to sixteen devices (the host and fifteen targets) can be attached to the SCSI bus. These are selected with jumpers on the Option Jumper Block or on Auxiliary Connector J1A (use either but not both); see Note in next column for J1A usage. In multiple-device systems, each device must have its own unique ID. SCSI ID 0 is Default.

SCSI ID	ID3	ID2	ID1	ID0	SCSI ID	ID3	ID2	ID1	ID0
0	-	-	-	-	8	✓	-	-	-
1	-	-	-	✓	9	✓	-	-	✓
2	-	-	✓	-	10	✓	-	✓	-
3	-	-	✓	✓	11	✓	-	✓	✓
4	-	✓	-	-	12	✓	✓	-	-
5	-	✓	-	✓	13	✓	✓	-	✓
6	-	✓	✓	-	14	✓	✓	✓	-
7	-	✓	✓	✓	15	✓	✓	✓	✓

✓ = jumper installed

Interface Termination

An external terminator provides termination for the interface lines.
Suggested end-of-cable terminator:
Methode DS2050-01-68D.

+5V to BUS (W1)

Jumper installed at W1 (Default) - Drive provides terminator power (TERMPWR) to the BUS.
Jumper omitted at W1- Host system provides TERMPWR.

Remote LED

Open-collector output - Used to drive a user-supplied LED to indicate the drive is active.

Spindle Control (SP0)

Jumper installed at SP0, jumper omitted at SP1 - Spindle motor starts when SCSI 'START UNIT' command is received.
Jumpers omitted at SP0 (Default) and at SP1 - Spindle motor starts at power-on.

Spindle Delay (SP1)

Jumper installed at SP1, jumper omitted at SP0 - Spindle motor start-up delayed based on SCSI ID (12 seconds per SCSI ID).
Jumpers omitted at SP1 (Default) and at SP0 - Spindle motor starts at power-on.

Write Protect (WP)

Jumper installed at WP - Drive is write protected.
Jumper omitted at WP (Default) - Drive is not write protected.

BUS Parity Check (PTY)

Jumper installed at PTY - Drive neither generates nor detects parity.
Jumper omitted at PTY (Default) - Drive generates parity and has parity detection enabled.

Spindle Synchronization (MSYNC and SSYNC)

Use of the MSYNC and SSYNC signals is optional. These signals are used as spindle synchronization reference.

Auxiliary Connector J1A:

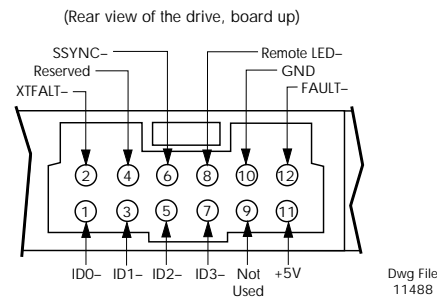

J1A is sampled at initialization for jumpers on pins 7-8, 5-6, 3-4, and 1-2 for SCSI ID3, ID2, ID1, and ID0 respectively; these connections (if not jumpered) are then released for use.

Drive Fault (XTFALT-)

Output signal negated (Default); indicates no drive fault.
Output signal asserted; indicates a drive fault condition.

Slave Sync (SSYNC-)

Use is optional; used as spindle synchronization reference.

Remote LED-

Open-collector output; used to drive a user-supplied LED to indicate the drive is active.

Ground (GND)

Logic ground; provides signal ground.

+5 Volts (+5V)

5 VDC (1A max); used to drive external LEDs.

Write Protect (FAULT-)

Input signal negated (Default); drive is *not* write protected.
Input signal asserted; drive is write protected.

A dash character (-) at the end of a signal name indicates it is asserted at the low level (active low) and negated at the high level.